

## Class 2: Electric Fields and Forces

# Attraction of a neutral object to another charge

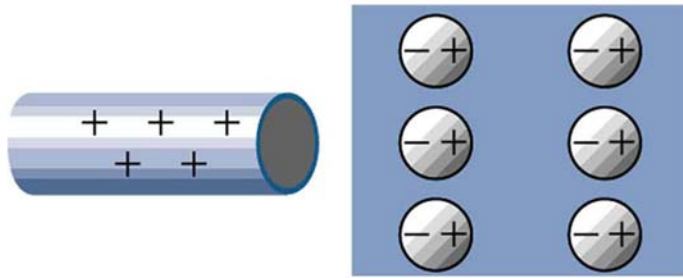

(a)

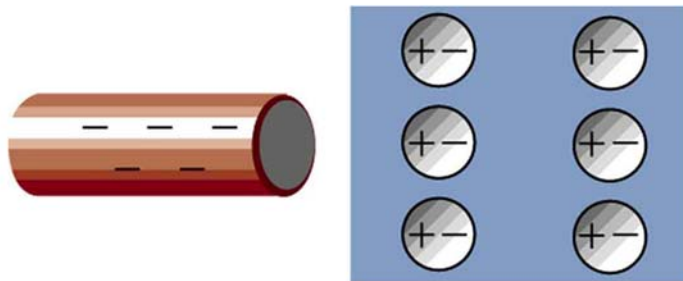

(b)

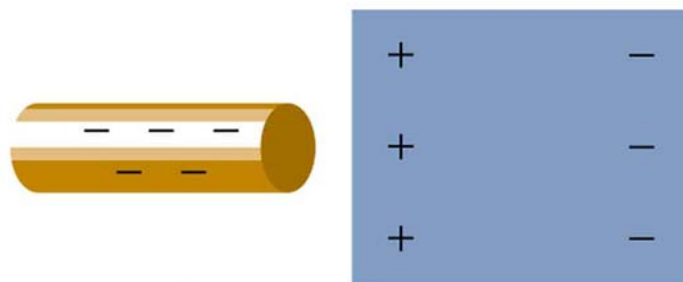

(c)

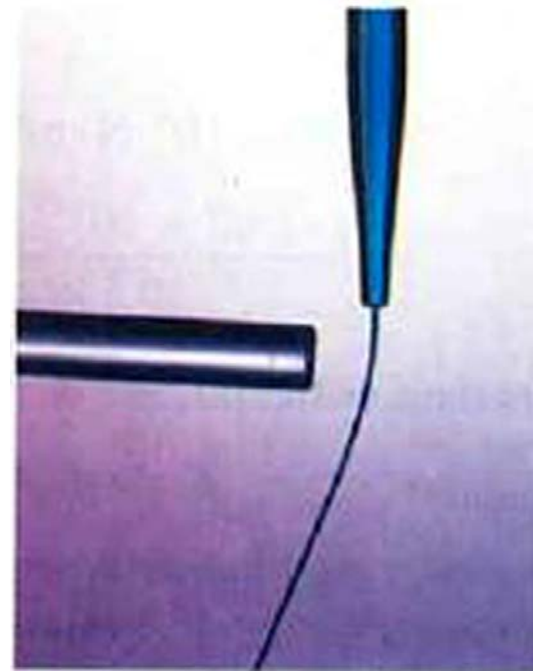

# Polarization

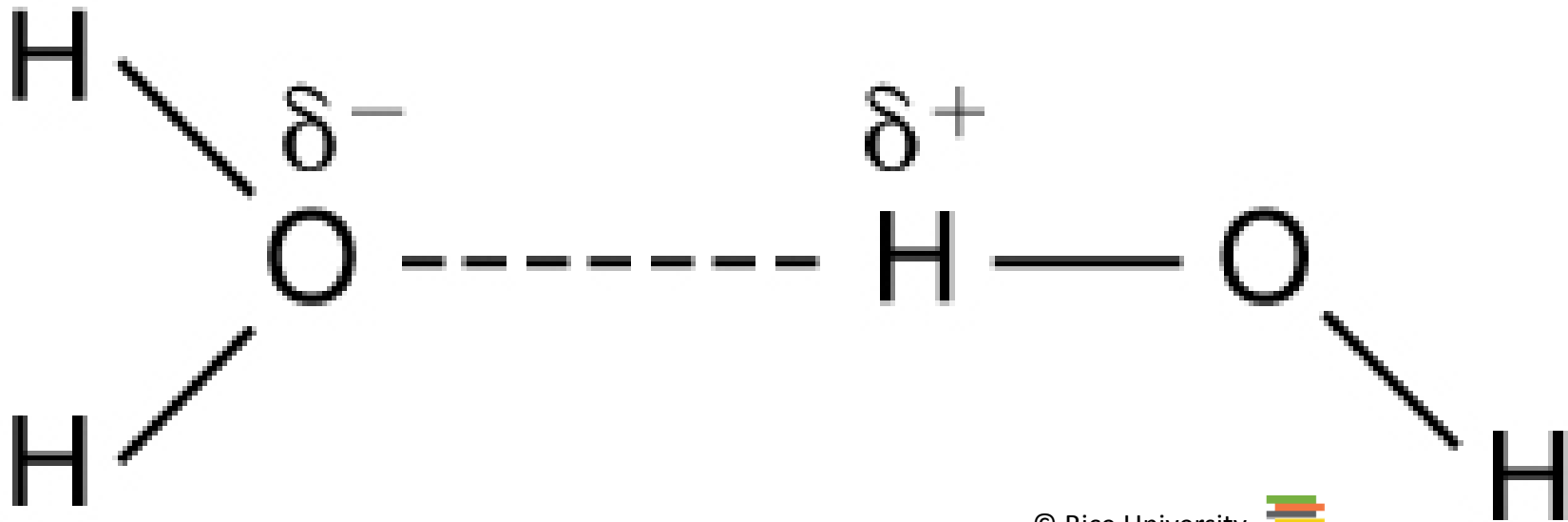

© Rice University 

Water molecule is neutral overall, but it actually has opposite charges at the two ends.

# Life is hold together by electrostatic forces



Distance between individual atoms  $\sim 3 \text{ \AA}$  or  $0.3\text{nm}$ .

Distance between strands  $\sim 1\text{nm}$

Charge  $\sim 2q_e$  per  $3\text{nm}$ .

# How a photocopier machine work

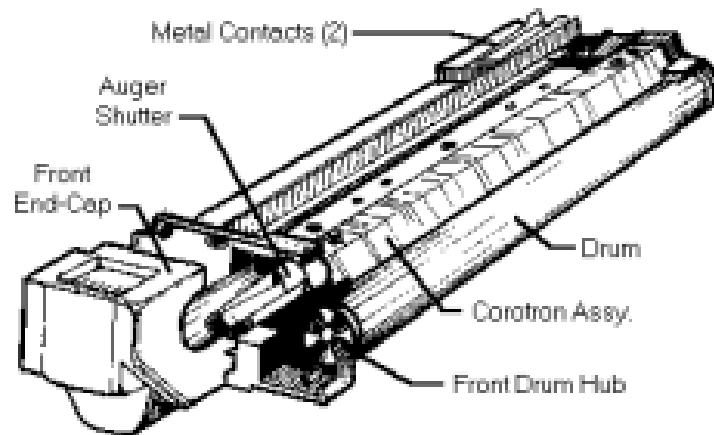
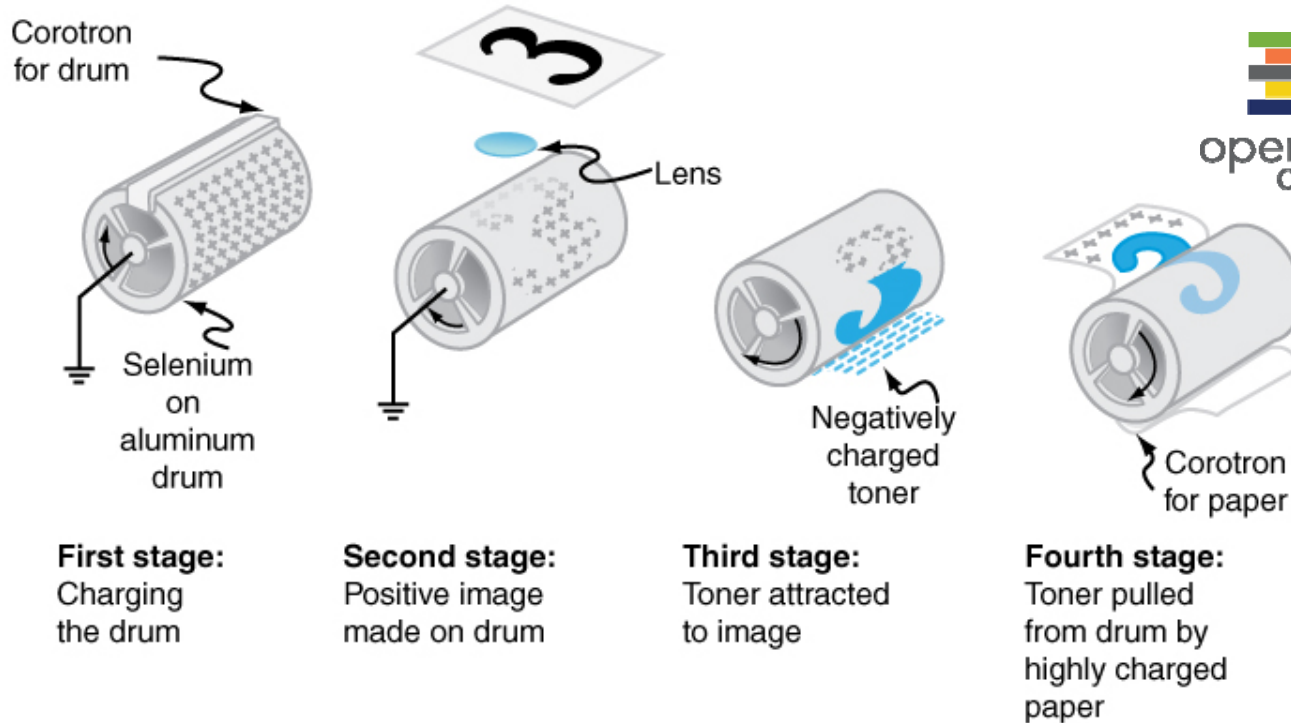

Selenium is a photoconductor

# Laser printer works by the same principle

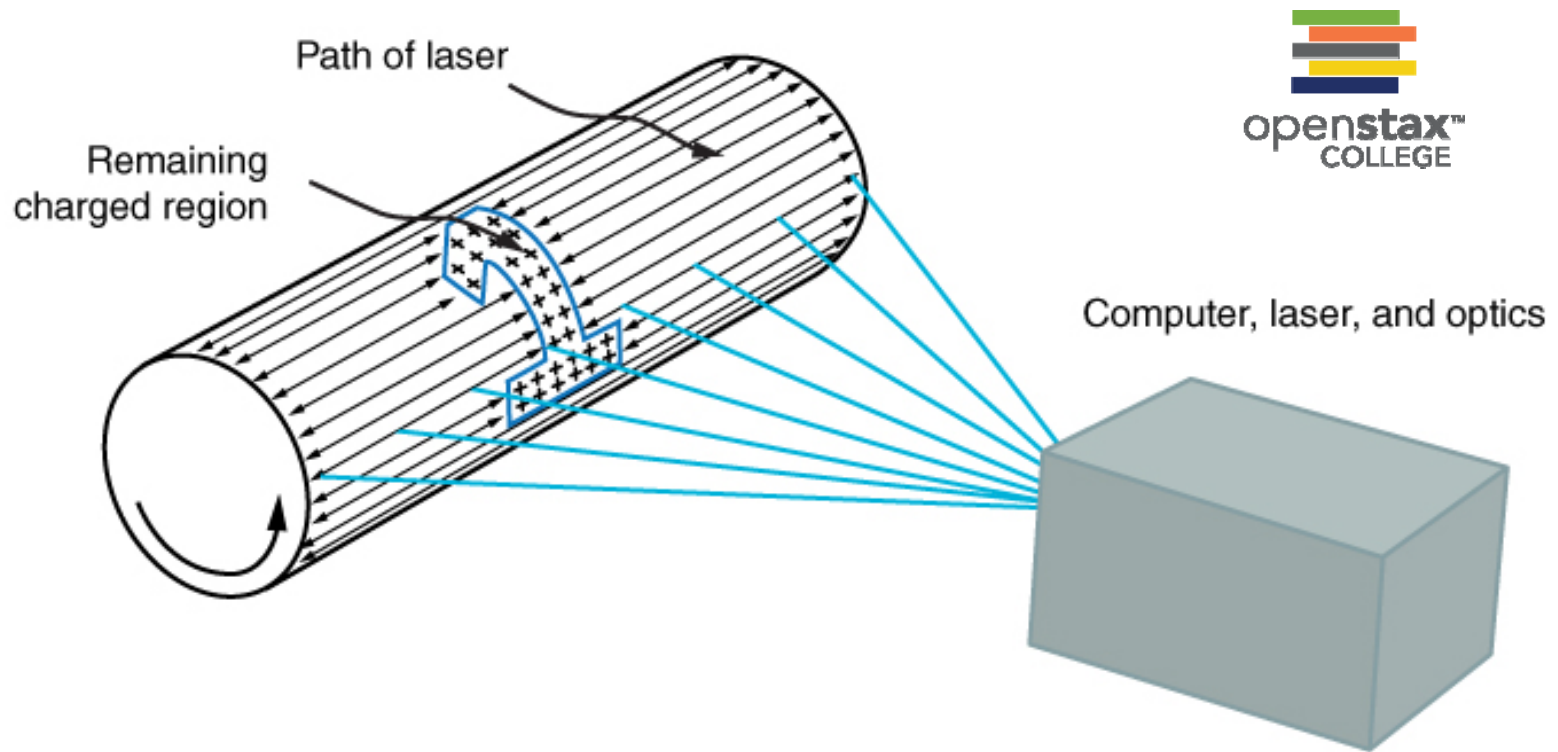

# Inkjet use electrostatics to control the position of the ink droplets

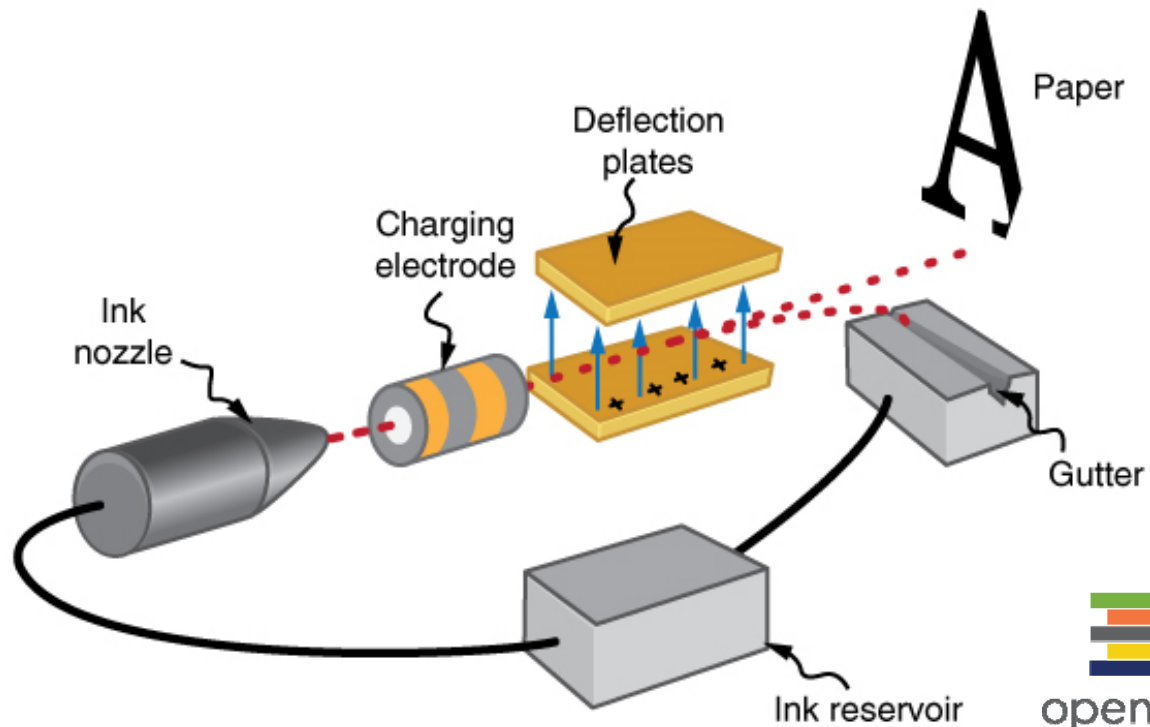

# Electric Field

Charges gives rise to electric fields. You can imagine electric fields as little arrows (vectors) attached to every point in the space.

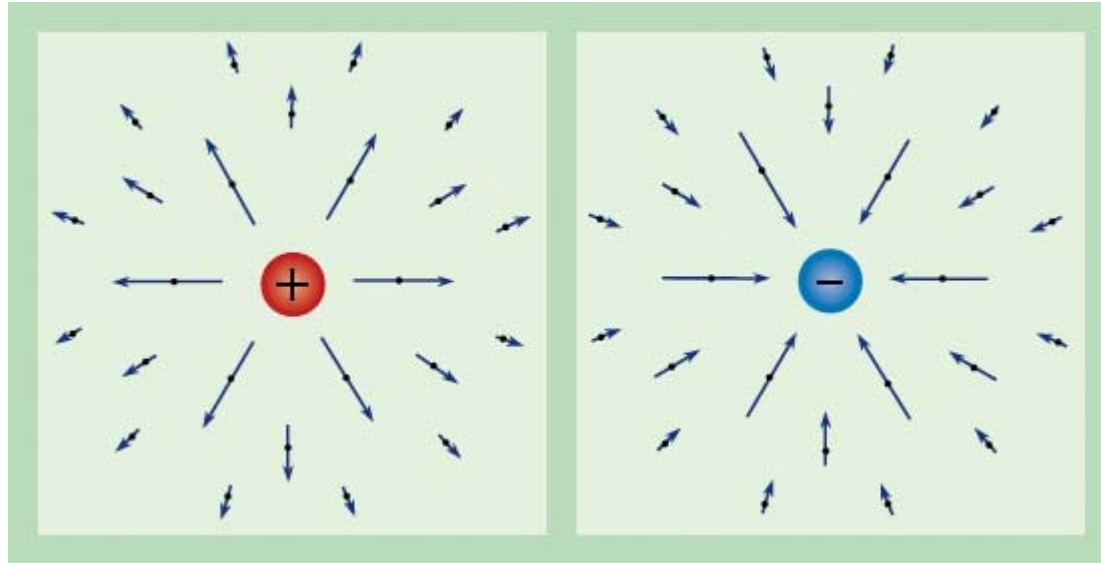

The charges that give rise to the electric field are called source charges.

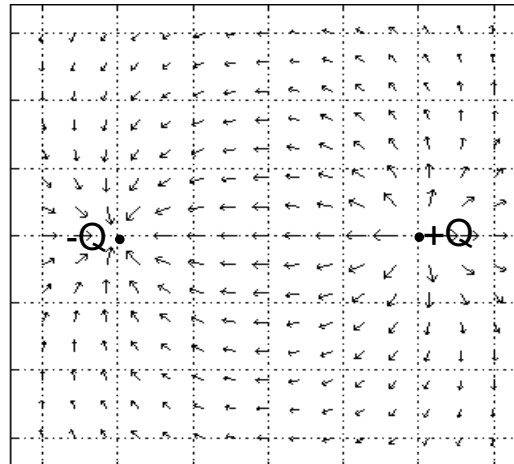

# Electric Field due to Point Charge

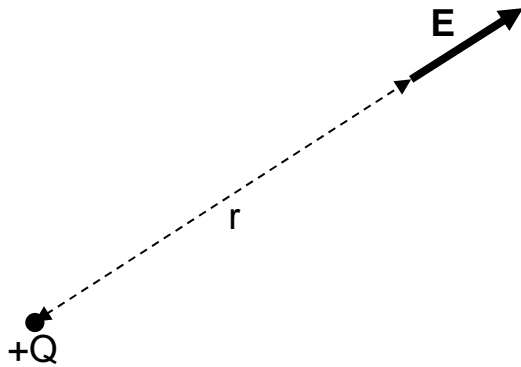

The electric field due to a positive point charge is pointing outward from the point charge

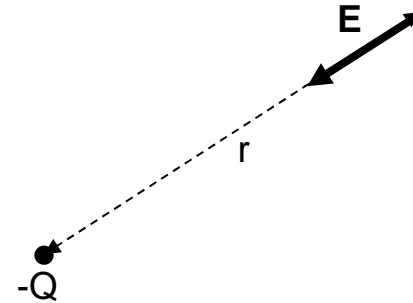

The electric field due to a negative point charge is pointing towards the point charge

In both cases, the magnitude of the electric field is given by:

$$|\mathbf{E}| = k \frac{|Q|}{r^2}$$

$$(k = 8.99 \times 10^9 \text{ N m}^2 / \text{C}^2)$$

# Coulomb's Law

To master this formula, you need to realize:

$$| \mathbf{E} | = k \frac{| Q |}{r^2}$$

$$(k = 8.99 \times 10^9 \text{ N m}^2 / \text{C}^2)$$

- (i) Electric field is a *vector*. You are not going to add electric fields like numbers!
- (ii) This equation only tell you the *magnitude* of the vector electric field (understand the meaning of absolute sign | |).
- (iii) How to determine the direction of the electric field (not shown by the equation).
- (iv) The units of electric field is N/C.
- (v) This is an inverse square law.
- (vi) The Q in this equation is always the source charge – you are calculating the electric field due to this charge.
- (vii) This equation only applies to a point charge.

# Electric Force on a Point Charge

When you point a charge in an electric field, there will be an electric force acting on it. In the case of a point charge:

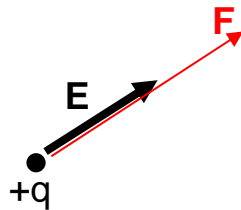

The electric force is in the same direction as the electric field if the point charge is a positive charge.

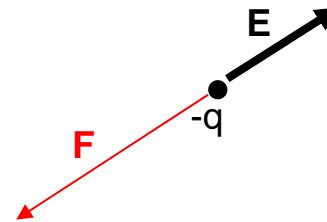

The electric force is in the opposite direction to the electric field if the point charge is a negative charge.

In both cases, the magnitude of the electric force is given by:

The charges that experience the electric field are called test charges.

$$| \mathbf{F} | = | q | | \mathbf{E} |$$

# Strategy in Electrostatic Problems

1. From the setting of the problem figure out which are the source charges and which are the test charges.
2. Apply  $|\mathbf{E}| = k \frac{|Q|}{r^2}$  only to source charges. You use this to calculate the electric fields due to these source charges.
3. Apply  $|\mathbf{F}| = |q| |\mathbf{E}|$  only to test charges. You use it to calculate the forces acting on the test charges when they are placed in an electric fields.
4. Don't forget force and electric field are vectors. You have to deal with them in the vectorial way!